

Small Kitchen Table

Made of 3/4" Birch plywood.

Top is a piece of 3/4" plywood and a piece of 1/2" plywood glued together. Make them oversized and trim to final dimension after gluing. The top surface can be covered in Formica for a more durable surface. Edging is Red Oak and is glued to the plywood using biscuit joints. The Oak makes a nice contrast to the Birch plywood.

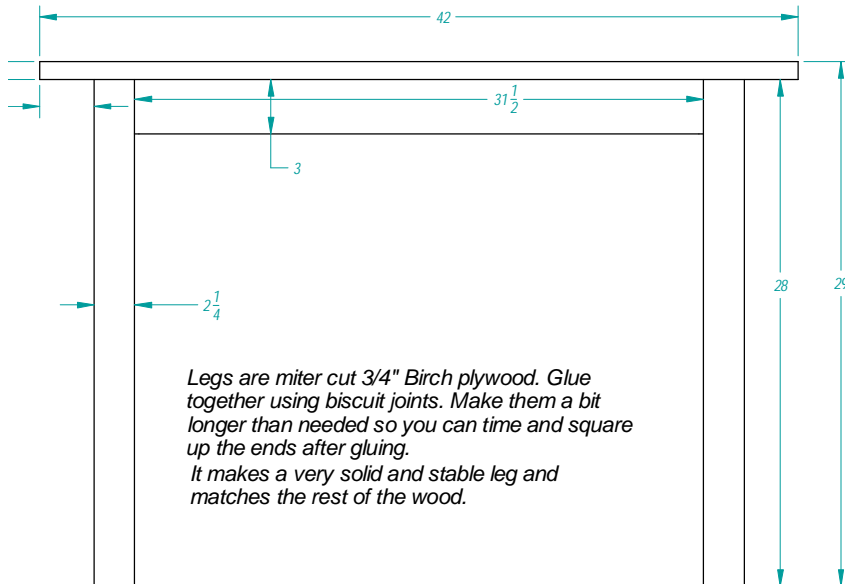
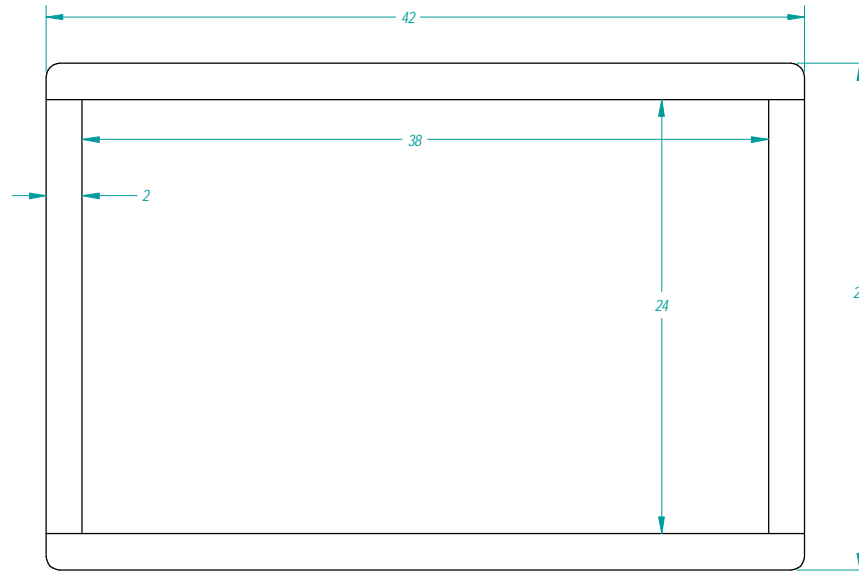

Legs are miter cut 3/4" Birch plywood. Glue together using biscuit joints. Make them a bit longer than needed so you can time and square up the ends after gluing. It makes a very solid and stable leg and matches the rest of the wood.

